



JABATAN PELAJARAN NEGERI TERENGGANU
PEPERIKSAAN PERCUBAAN
PENILAIAN MENENGAH RENDAH 2011

SCIENCE/SAINS

Paper 1/Kertas 1

One hour/Satu jam

DO NOT OPEN THIS QUESTION PAPER UNTIL YOU ARE TOLD TO DO SO
JANGAN BUKA KERTAS SOALAN INI SEHINGGA DIBERITAHU

1. **This question paper consists of 40 questions.**
Kertas soalan ini mengandungi 40 soalan.
2. **Answer all questions.**
Jawab semua soalan.
3. **Each question is followed by four alternative answers, A, B, C or D. For each question, choose one answer only. Blacken your answer on your objective answer sheet provided.**
Tiap-tiap soalan diikuti oleh empat pilihan jawapan, iaitu A, B, C dan D. Bagi setiap soalan, pilih satu jawapan sahaja. Hitamkan jawapan anda pada kertas jawapan objektif yang disediakan.
4. **If you wish to change your answer, erase the blackened mark that you have made. Then blacken the new answer.**
Sekiranya anda hendak menukar jawapan, padamkan tanda yang telah dibuat. Kemudian hitamkan jawapan yang baru.
5. **The diagrams in the questions provided are not drawn to scale unless stated.**
Rajah yang mengiringi soalan tidak dilukis mengikut skala kecuali dinyatakan.
6. **You may use a non-programmable scientific calculator.**
Anda dibenarkan menggunakan kalkulator saintifik yang tidak boleh diprogram.

TERENGGANU NEGERI ANJUNG ILMU

Disediakan oleh:
Guru AKRAM Terengganu

Dengan kerjasama:
MPSM Negeri Terengganu

Dibiayai oleh:
Kerajaan Negeri Terengganu

Dicetak oleh:
Percetakan Yayasan Islam Terengganu Sdn. Bhd.
Telefon: 609-666 8611/6652/8601 Faks: 609-666 0611/0063

This question paper consists of 17 printed pages
Kertas soalan ini mengandungi 17 halaman bercetak

- 1 Table 1 shows the physical quantities X and Y and their SI units.
Jadual 1 menunjukkan unit SI bagi kuantiti fizik X dan Y.

Physical quantity <i>Kuantiti fizik</i>	SI unit <i>Unit SI</i>
X	Second <i>Saat</i>
Y	Metre <i>Meter</i>

Table 1 / *Jadual 1*

Which of the following represents X and Y?
Antara berikut yang manakah mewakili X dan Y?

	X	Y
A	Time <i>Masa</i>	Electric current <i>Arus elektrik</i>
B	Length <i>Panjang</i>	Mass <i>Jisim</i>
C	Time <i>Masa</i>	Length <i>Panjang</i>
D	Mass <i>Jisim</i>	Temperature <i>Suhu</i>

- 2 Diagram 1 shows a unicellular organism.
Rajah 1 menunjukkan satu organisma unisel

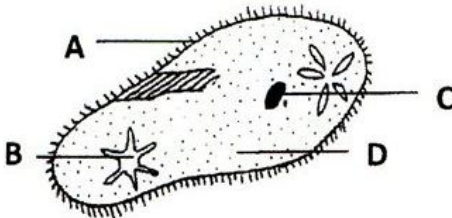
Diagram 1 / *Rajah 1*

Which part of the cell, A, B, C or D control the activity of the cell?
Bahagian sel yang manakah A, B, C atau D yang mengawal aktiviti sel?

- 3 Table 2 shows the densities of four substances J, K, L and M.
Jadual 2 menunjukkan ketumpatan empat bahan J, K, L dan M.

Substance <i>Bahan</i>	J	K	L	M
Density / g/cm^3 <i>Ketumpatan / g/cm^3</i>	1.5	13.5	10.5	2.6

Table 2 / *Jadual 2*

Which of the following substances will float on a liquid that has density of 3.5 g/cm^3 ?
Antara bahan-bahan berikut, yang manakah akan terapung di atas cecair yang berketumpatan 3.5 g/cm^3 ?

- A J and K
J dan K
- B K and L
K dan L
- C L and M
L dan M
- D J and M
J dan M
- 4 The following are the importance of a certain natural resource.
Berikut merupakan kepentingan suatu sumber semulajadi.

- Cools the plants through the process of transpiration
Menyejukkan tumbuhan melalui proses transpirasi
- Provides buoyancy support to aquatic plant
Membekalkan daya apungan kepada tumbuhan akuatik
- Controls and retains body temperature at 37°C
Mengawal dan mengekalkan suhu badan pada 37°C

The natural resource referred to is
Sumber semulajadi itu ialah

- A Minerals
Mineral
- B Fossil fuel
Bahan api fosil
- C Soil
Tanah
- D Water
Air

5 Diagram 2 shows percentage of gases in the air.
Rajah 2 menunjukkan peratus gas di dalam udara.

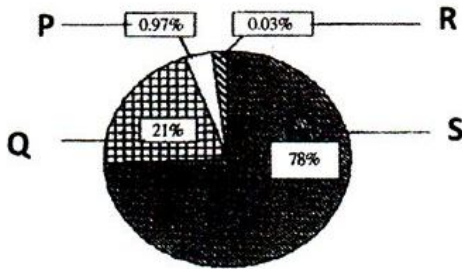

Diagram 2 / *Rajah 2*

Which of the following is true about gas Q?
Antara berikut yang manakah benar tentang gas berlabel Q?

- A Needed for respiration
Diperlukan untuk respirasi
- B Needed for photosynthesis
Diperlukan untuk fotosintesis
- C Thinning of the ozone layer
Menipiskan lapisan ozon
- D Turns lime water cloudy
Mengeruhkan air kapur

6 Diagram 3 shows three grasshopper are placed in the bell jar.
Rajah 3 menunjukkan tiga belalang diletakkan di dalam serkup kaca.



Diagram 3 / *Rajah 3*

Which of the following shows the correct changes in the composition of air after 30 minutes?

Antara berikut yang manakah menunjukkan komposisi udara yang betul selepas 30 minit?

	Oxygen <i>Oksigen</i>	Carbon dioxide <i>Karbon dioksida</i>
A	Increases <i>Meningkat</i>	Decreases <i>Menurun</i>
B	Decreases <i>Menurun</i>	Decreases <i>Menurun</i>
C	Decreases <i>Menurun</i>	Increases <i>Meningkat</i>
D	Increases <i>Meningkat</i>	Increases <i>Meningkat</i>

- 7 Diagram 4 shows a boy throwing a ball up and another boy on the first floor of the building is catching it.
Rajah 4 menunjukkan seorang budak lelaki melambungkan sebiji bola dan seorang budak lelaki lain menangkap bola itu di tingkat satu sebuah bangunan.



Diagram 4 / Rajah 4

What happens to the kinetic energy and potential energy?
Apakah yang berlaku kepada tenaga kinetik dan tenaga keupayaan?

	Potential energy <i>Tenaga keupayaan</i>	Kinetic energy <i>Tenaga kinetik</i>
A	Increase <i>Bertambah</i>	Decrease <i>Berkurang</i>
B	Decrease <i>Berkurang</i>	Increase <i>Bertambah</i>
C	Decrease <i>Berkurang</i>	Decrease <i>Berkurang</i>
D	Increase <i>Bertambah</i>	Increase <i>Bertambah</i>

- 8 Diagram 5 shows an electric power station.
Rajah 5 menunjukkan sebuah stesen janakuasa elektrik

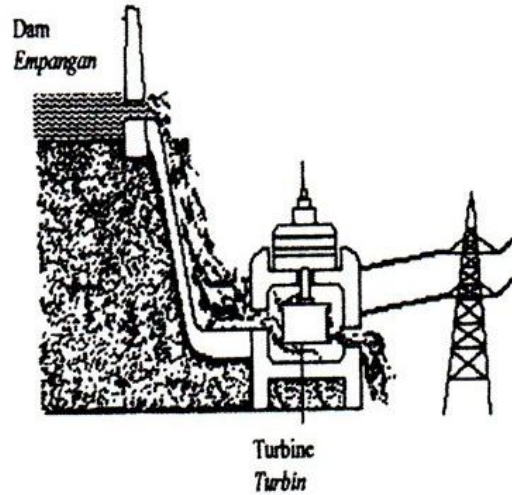

Diagram 5 / Rajah 5

What is the source of energy used at this power station?
Apakah sumber tenaga yang digunakan di stesen janakuasa ini?

- A Wind
Angin
- B Water
Air
- C The sun
Matahari
- D Geothermal
Geoterma

- 9 Diagram 6 shows the ice in the bowl has melted.
Rajah 6 menunjukkan ais di dalam mangkuk melebur.



Diagram 6 / Rajah 6

Why did the process happened?
Mengapakah proses ini berlaku?

- A Particles of ice absorb heat
Zarah-zarah ais menyerap haba
- B Particles of ice radiate heat
Zarah-zarah ais menyinar haba
- C Particles of ice reflect heat
Zarah-zarah ais memantul haba
- D Particles of ice release heat
Zarah-zarah ais membebaskan haba
- 10 Diagram 7 shows two workers P and Q wearing different coloured uniforms working on a hot day. Worker P sweats more than worker Q.
Rajah 7 menunjukkan dua pekerja, P dan Q memakai pakaian seragam berlainan warna bekerja di hari yang panas. Pekerja P berpeluh lebih banyak daripada pekerja Q.



Diagram 7 / Rajah 7

What can be concluded from the above situation?
Apakah kesimpulan dari situasi di atas?

- A Black uniform releases heat better than white uniform
Pakaian seragam hitam membebaskan haba lebih baik daripada pakaian seragam putih.
- B White uniform releases heat better than black uniform
Pakaian seragam putih membebaskan haba lebih baik daripada pakaian seragam hitam
- C Black uniform absorbs heat better than white uniform
Pakaian seragam hitam menyerap haba lebih baik daripada pakaian seragam putih
- D White uniform absorbs heat better than black uniform
Pakaian seragam putih menyerap haba lebih baik daripada pakaian seragam hitam

- 11 Diagram 8 shows the incident ray and the reflected ray from a light source that is projected on a plane mirror.
Rajah 8 menunjukkan sinar tuju dan sinar pantulan daripada satu sumber cahaya yang dipancarkan kepada cermin satah.

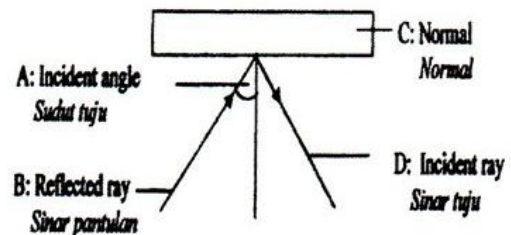

Diagram 8 / Rajah 8

Which part A, B, C or D is correctly labelled?
Bahagian manakah A, B, C dan D dilabelkan dengan betul?

- 12 Diagram 9 shows a plant that was left for two weeks during an experiment.
Rajah 9 menunjukkan eksperimen ke atas tumbuhan yang ditinggalkan selama dua minggu.

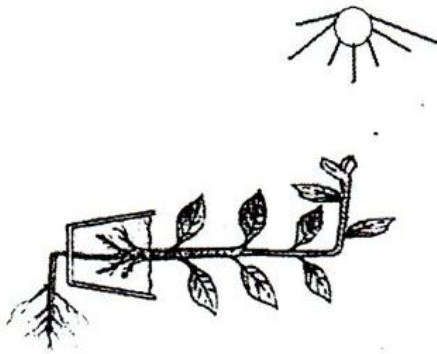

Diagram 9 / Rajah 9

State the stimuli that cause this type of response in the root and the shoot of the plant.

Nyatakan rangsangan yang menghasilkan jenis gerak balas pada akar dan pucuk tumbuhan itu.

	Root <i>Akar</i>	Shoot <i>Pucuk</i>
A	Touch <i>Sentuhan</i>	Water <i>Air</i>
B	Gravity <i>Graviti</i>	Water <i>Air</i>
C	Touch <i>Sentuhan</i>	Gravity <i>Graviti</i>
D	Gravity <i>Graviti</i>	Light <i>Cahaya</i>

- 13 Diagram 10 shows the parts of the digestive system.
Rajah 10 menunjukkan sebahagian daripada sistem pencernaan manusia.

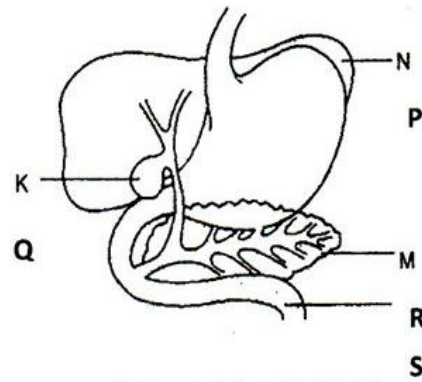

Diagram 10 / Rajah 10

Which part labelled P, Q, R and S shows the correct function?

Bahagian manakah yang berlabel P, Q, R dan S menunjukkan fungsinya yang betul?

	Part <i>Bahagian</i>	Function <i>Fungsi</i>
A	P	To secrete insulin <i>Untuk merembeskan insulin</i>
B	Q	To store bile <i>Untuk menyimpan hempedu</i>
C	R	To secrete hydrochloric acid <i>Untuk merembeskan asid hidroklorik</i>
D	S	To reabsorb water <i>Untuk menyerap semula air</i>

- 14 Diagram 11 shows processes in the human digestive system.
Rajah 11 menunjukkan proses-proses dalam sistem pencernaan manusia.

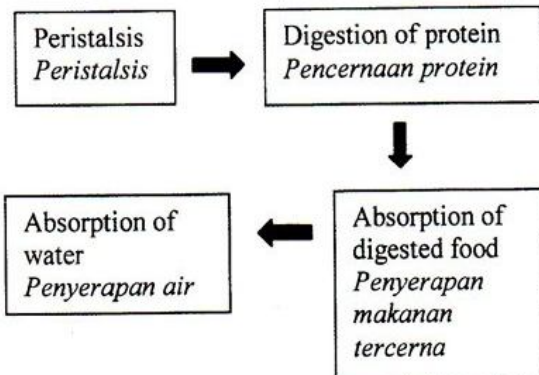

Diagram 11 / Rajah 11

Which of the following shows the correct sequence of organs involved in the processes?

Antara berikut yang manakah menunjukkan susunan yang betul organ-organ yang terlibat dalam proses-proses tersebut?

A	Small intestine <i>Usus kecil</i>	Large intestine <i>Usus besar</i>	Oesophagus <i>Esofagus</i>	Stomach <i>Perut</i>
B	Large intestine <i>Usus besar</i>	Stomach <i>Perut</i>	Oesophagus <i>Esofagus</i>	Small intestine <i>Usus kecil</i>
C	Oesophagus <i>Esofagus</i>	Stomach <i>Perut</i>	Small intestine <i>Usus kecil</i>	Large intestine <i>Usus besar</i>
D	Stomach <i>Perut</i>	Small intestine <i>Usus kecil</i>	Oesophagus <i>Esofagus</i>	Large intestine <i>Usus besar</i>

15 Diagram 12 shows three animals K, L and M
Rajah 12 menunjukkan tiga haiwan K, L dan M.



K



L



M

Diagram 12 / Rajah 12

What is the common characteristic of animals K, L and M?

Apakah ciri sepunya bagi haiwan K, L dan M?

- A Body covered with scales
Badan diselaputi sisik
- B Breathe through moist skin
Bernafas melalui kulit lembap
- C Body covered with fur
Badan di selaputi bulu
- D Cold blooded animals
Haiwan berdarah sejuk

16 Diagram 13 shows a food web in a paddy field.

Rajah 13 menunjukkan siratan makanan di sawah padi.

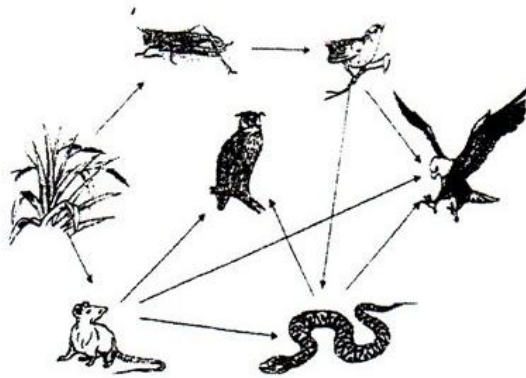

Diagram 13 / Rajah 13

Which organisms can be classified as secondary consumers as well as tertiary consumers?

Organisma manakah boleh dikelaskan sebagai pengguna sekunder dan juga pengguna tertier?

- A Small bird and eagle
Burung kecil dan helang
- B Small bird, owl and snake
Burung kecil, burung hantu dan ular
- C Owl, small bird, snake and eagle
Burung hantu, burung kecil. Ular dan helang
- D Snake, owl and eagle
Ular, burung hantu dan helang

- 17 Diagram 14 shows the stages in water purification
Rajah 14 menunjukkan peringkat-peringkat pembersihan air.

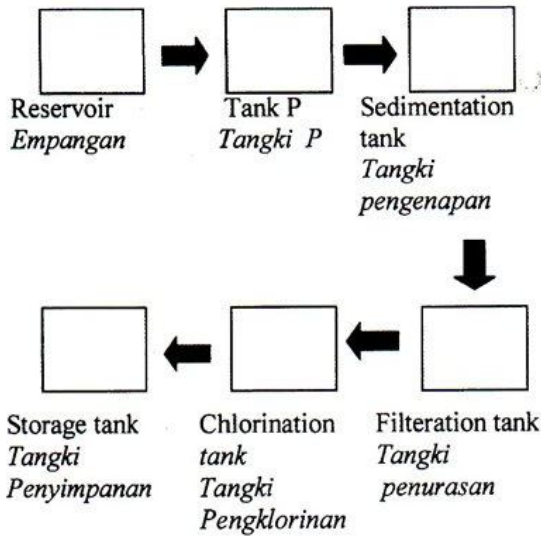
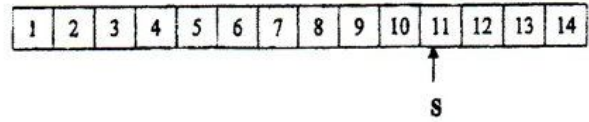

Diagram 14 / *Rajah 14*

What substance added in tank P and its purpose is correct?
Apakah bahan yang ditambah di dalam tangki P dan tujuannya adalah betul?

	Substance <i>Bahan</i>	Purpose <i>Tujuan</i>
A	Chlorine <i>Klorin</i>	To kill microorganisms <i>Untuk membunuh mikroorganisma</i>
B	Slaked lime <i>Kapur mati</i>	To purify the water <i>Untuk menuliskan air</i>
C	Alum <i>Alum</i>	To coagulate impurities in water <i>Untuk menggumpalkan kekotoran di dalam air</i>
D	Fluorine <i>Fluorin</i>	To remove soluble impurities from the water <i>Untuk membuang bendasing terlarut dalam air</i>

- 18 The chart below shows the pH value of substance S.
Carta di bawah menunjukkan nilai pH bahan S.



Which of the following may be substance S?
Antara berikut yang manakah kemungkinan bahan S?

- A Orange juice
Jus oren
- B Distilled water
Air suling
- C Lime water
Air kapur
- D Hot coffee
Kopi panas

- 19 Diagram 15 shows syringe used to suck up water but the water did not rise up.
Rajah 15 menunjukkan satu picagari digunakan untuk menyedut air tetapi air tidak masuk.

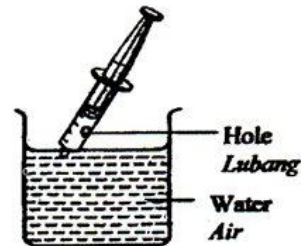

Diagram 15 / *Rajah 15*

Which statement is true about air pressure in the syringe?

Pernyataan manakah benar mengenai tekanan udara di dalam picagari?

- A Higher than the water pressure
Lebih tinggi daripada tekanan air
- B Lower than the atmospheric pressure
Lebih rendah daripada tekanan atmosfera
- C Lower than the water pressure
Lebih rendah daripada tekanan air
- D Same as the atmospheric pressure
Sama dengan tekanan atmosfera

- 20 Diagram 16 shows a student with a mass of 60kg carrying a box with 10kg.
Rajah 16 menunjukkan seorang pelajar berjisim 60kg membawa sebuah kotak berjisim 10kg

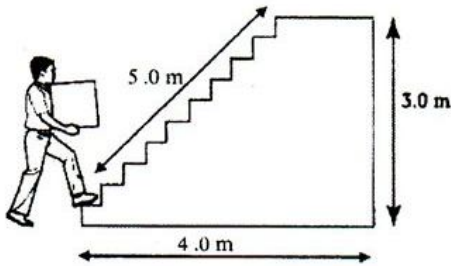

Diagram 16 / *Rajah 16*

Calculate the work done by the student.
Hitungkan kerja yang dilakukan oleh pelajar itu. [1 kg = 10 N]

Work done = force x distance

Kerja = daya x jarak

- A 2100J
- B 3100J
- C 2800J
- D 1800J

- 21 In which of the following conditions, force is produced?

Antara keadaan berikut, yang manakah daya dihasilkan?

- A Holding a spring
Memegang spring
- B Putting a nail on a table
Meletakkan paku di atas meja
- C Pulling back the string of a bow
Menarik tali busur
- D Touching a static car at a roadside
Menyentuh kereta pegun di tepi jalan

- 22 Diagram 17 shows a skeleton system of an elephant

Rajah 17 menunjukkan sistem rangka pada seekor gajah.

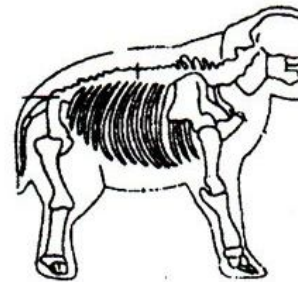

Diagram 17 / *Rajah 17*

Which of the following is not the function of the endoskeleton of an elephant?

Antara berikut, yang manakah bukan fungsi rangka dalam bagi seekor gajah?

- A To support the weight of the body
Untuk menyokong berat badannya
- B To support the body and give it shape
Untuk menyokong dan memberi bentuk kepada badannya
- C To protect the internal organs of the body
Untuk melindungi organ dalaman badan
- D To help it float in water
Untuk membantunya terapung di dalam air.

- 23 Diagram 18 shows two stools of different height.
Rajah 18 menunjukkan dua bangku yang berbeza ketinggian.

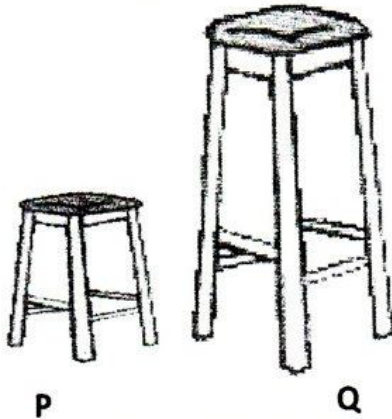

Diagram 18 / Rajah 18

Why stool P more stable than Q?
Mengapakah bangku P lebih stabil daripada Q?

- A P is lighter than Q
P lebih ringan daripada Q
- B Q is higher than P
Q lebih tinggi daripada P
- C The position of centre of gravity Q is lower than P
Kedudukan pusat graviti Q lebih rendah daripada P
- D The position of centre of gravity P is lower than Q
Kedudukan pusat graviti P lebih rendah daripada Q

- 24 Diagram 19 shows a type lever.
Rajah 19 menunjukkan sejenis tuas.

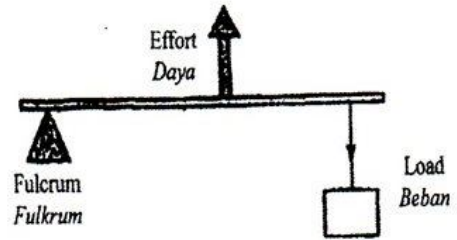

Diagram 19 / Rajah 19

Which of the following has the same class of lever shown above?

Antara berikut yang manakah menunjukkan kelas sistem tuas yang sama seperti di atas?

- A Scissors
Gunting
- B Broom
Penyapu
- C See-saw
Jongkang-jongkit
- D Paper cutter
Pemotong kertas

- 25 Diagram 20 shows a see-saw that is balanced
Rajah 20 menunjukkan sebuah jungkang-jongkit berada di dalam keadaan seimbang.

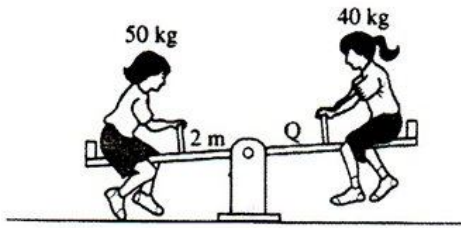

Diagram 20 / *Rajah 20*

What is the distance labelled Q?
Apakah jarak berlabel Q?

- A 1.5 m
 - B 2.5 m
 - C 3.5 m
 - D 4.0 m
- 26 Diagram 21 shows a part of the human respiratory system in which gaseous exchange takes place.
Rajah 21 menunjukkan sebahagian daripada sistem respirasi manusia di mana berlakunya pertukaran gas.

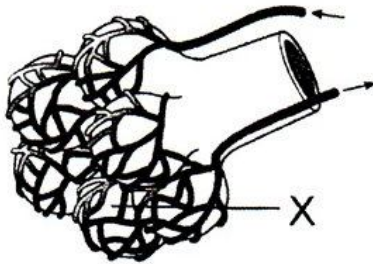

Diagram 21 / *Rajah 21*

What is the characteristic of X to increase the rate of oxygen diffusion?
Apakah ciri X yang boleh menambahkan kadar resapan oksigen?

- A Thick wall
Dinding tebal
- B It has a dry surface area
Mempunyai permukaan yang kering
- C Surrounded by arteries
Dikelilingi oleh arteri
- D Surrounded by a network of blood capillaries
Dikelilingi oleh jaringan kapilari darah

- 27 Diagram 22 shows the transport of gas in blood vessels.
Rajah 22 menunjukkan pengangkutan gas di dalam salur darah.

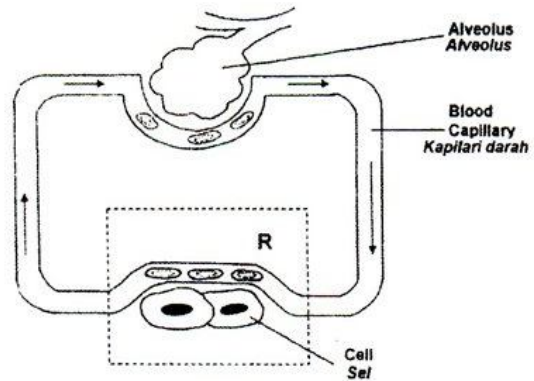

Diagram 22 / *Rajah 22*

Based on Diagram 22, what happens at stages R?
Berdasarkan Rajah 22, apakah yang berlaku pada peringkat R?

- A Carbon dioxide is used by the cells for respirations
Karbon dioksida digunakan oleh sel untuk respirasi
- B Oxygen diffuses out of the blood capillaries into the cells
Oksigen meresap keluar dari kapilari darah ke dalam sel
- C Oxygen diffuses from the cells into the blood capillaries
Oksigen meresap dari sel ke dalam kapilari darah
- D Carbon dioxide combines with haemoglobin to form oxyhaemoglobin
Karbon dioksida berpadu dengan haemoglobin untuk membentuk oksihemoglobin

28 Diagram 23 shows two components of blood.
Rajah 23 menunjukkan dua komponen darah.

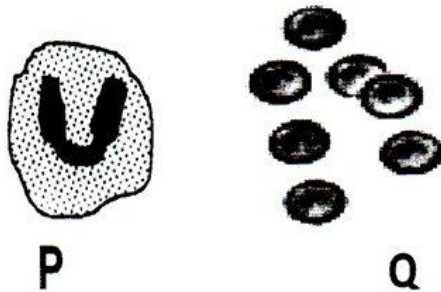
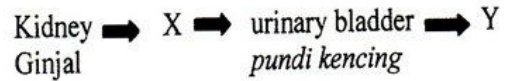

Diagram 23 / Rajah 23

What are the function of component P and Q?
Apakah fungsi komponen P dan Q?

	P	Q
A	Fight infections Melawan jangkitan	Helps in blood clotting Membantu dalam pembekuan darah
B	Transport oxygen Mengangkut oksigen	Fight infections Melawan jangkitan
C	Fight infections Melawan jangkitan	Transport oxygen Mengangkut oksigen
D	Transport hormone Mengangkut hormon	Transport waste product Mengangkut bahan buangan

29 The information below shows the flow of urine removed from the human body.
Maklumat di bawah menunjukkan aliran air kencing dibuang dari badan.



What are X and Y?
Apakah X dan Y?

	X	Y
A	Urethra Uretra	Blood vessel Salur darah
B	Urethra Uretra	Ureter Ureter
C	Ureter Ureter	Urethra Uretra
D	Blood vessel Salur darah	Ureter Ureter

30 Diagram 24 shows some processes and development occurs in the female reproductive system.
Rajah 24 menunjukkan beberapa proses dan perkembangan yang berlaku di dalam sistem pembiakan perempuan.

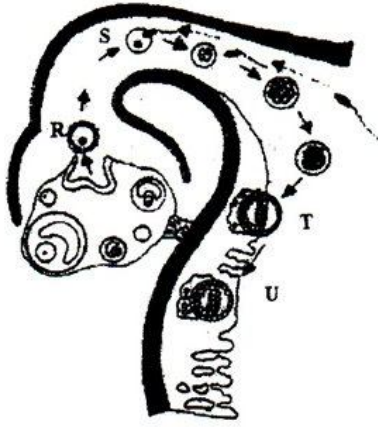

Diagram 24 / Rajah 24

What development occurs from stage S to stage U?

Apakah perkembangan yang berlaku di peringkat S hingga peringkat U?

- A Ovulation
Ovulasi
- B Cell division
Pembahagian sel
- C Cell germination
Percambahan sel
- D Repeated fertilization
Persenyawaan berulang

31 Diagram 25 shows a structure P produced by a part of a flower.

Rajah 25 menunjukkan struktur P yang dihasilkan suatu bahagian pada bunga.

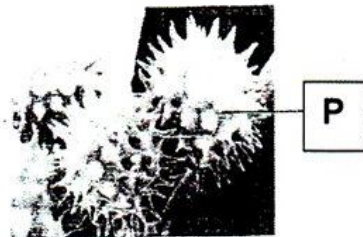
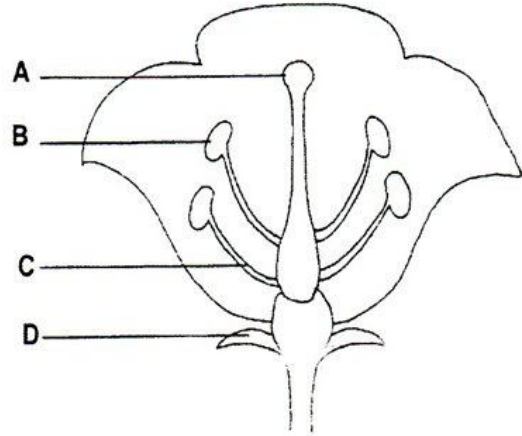

Diagram 25 / Rajah 25

Which part of a flower, A, B, C or D produces P?

Bahagian manakah pada bunga, A, B, C atau D menghasilkan P?



32 Which of the following physical characteristics are used to measure growth?

Antara ciri fizikal berikut, yang manakah digunakan untuk mengukur pertumbuhan?

- I Height
Ketinggian
- II Body weight
Berat badan
- III Colour of skin
Warna kulit

- A I and II only
I dan II sahaja
- B I and III only
I dan III sahaja
- C II and III only
II dan III sahaja
- D I, II and III
I, II dan III

- 33 Diagram 26 shows an apparatus set-up.
Rajah 26 menunjukkan satu susunan radas.

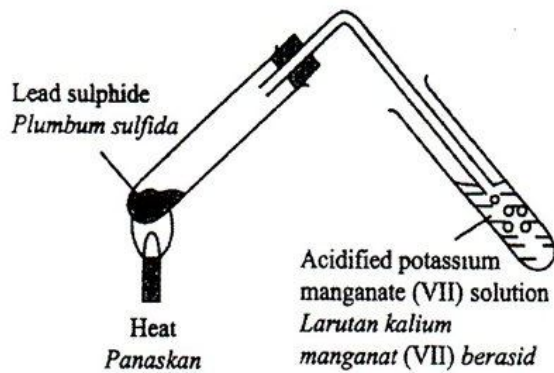

Diagram 26 / Rajah 26

What is the colour of acidified potassium manganate (VII) solution at the end of the experiment?

Apakah warna larutan kalium manganat (VII) berasid pada akhir eksperimen?

- A Colourless
Tidak berwarna
- B White
Putih
- C Blue
Biru
- D Purple
Ungu
- 34 Diagram 27 shows a fractional distillation tower used in the petrochemical industry to purify petroleum.
Rajah 27 menunjukkan menara penyulingan berperingkat yang digunakan dalam industr petrokimia untuk menapis petroleum.

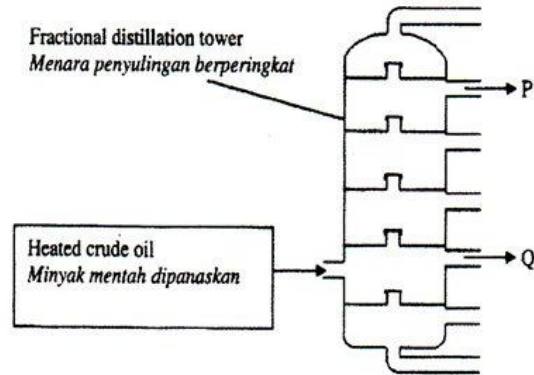

Diagram 27 / Rajah 27

Compared to fraction Q, fraction P has..

Berbanding dengan pecahan Q, pecahan P mempunyai...

- A a lower boiling point
takat didih yang lebih rendah
- B a darker colour
warna yang lebih gelap
- C larger molecules
molekul yang lebih besar
- D a higher viscosity
kelikatan yang lebih tinggi
- 35 Diagram 28 shows a parallel circuit with two identical bulbs, R and S.
Rajah 28 menunjukkan satu litar selari dengan dua mentol yang serupa, R dan S

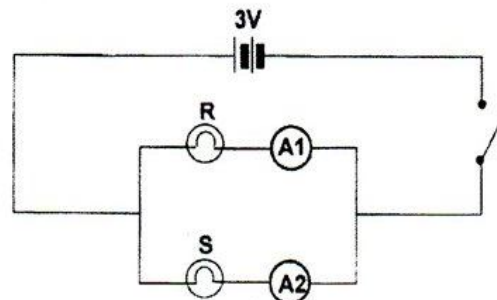

Diagram 28 / Rajah 28

The resistance of each bulb is 2Ω . What is the reading of ammeter A_2 if the switch in this circuit is on?

Rintangan setiap mentol ialah 2Ω . Apakah bacaan ammeter A_2 jika suis dalam litar ini dihidupkan?

Current (I)	=	$\frac{\text{voltage(V)}}{\text{Resistance}(\Omega)}$
Arus (I)	=	$\frac{\text{voltan(V)}}{\text{Rintangan}(\Omega)}$

- A 1.5 A
 B 3.0 A
 C 4.0 A
 D 4.5 A

36 Diagram 29 shows a negatively-charged of electroscopes.

Rajah 29 menunjukkan elektroskop bercas negatif.

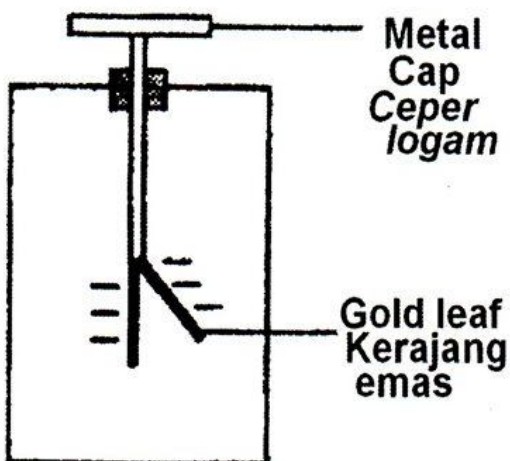

Diagram 29 / Rajah 29

What happens to the gold leaf when a negatively-charged rod is brought near the metal cap?

Apakah yang berlaku kepada kerajang emas apabila rod bercas negatif dibawa mendekati ceper logam?

- A There is no change
Tiada perubahan
- B The gold leaf diverges further
Kerajang emas mencapah lebih jauh
- C The divergence of the gold leaf decreases
Kepesongan kerajang emas berkurang
- D The divergence of the gold leaf increases and then decreases
Kepesongan kerajang emas bertambah dan kemudian berkurang

37 Diagram 30 shows a type of transformer.

Rajah 30 menunjukkan sejenis transformer.

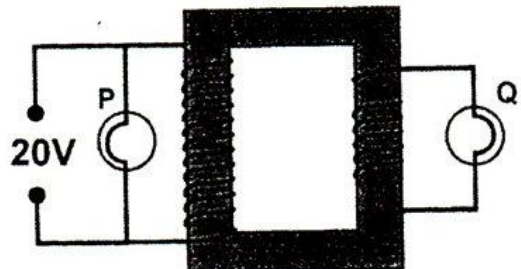

Diagram 30 / Rajah 30

Which of the following statements is correct?
Antara berikut, pernyataan yang manakah betul?

- A Bulb P does not light up
Mentol P tidak menyala
- B Bulb P is brighter than bulb Q
Mentol P lebih cerah daripada mentol Q
- C Bulb Q is brighter than bulb P
Mentol Q lebih cerah daripada mentol P
- D Bulbs P and Q have the same brightness
Mentol P dan Q mempunyai kecerahan yang sama
- 38 An air conditioner has a power and voltage rating of 900 W, 240 V is used for 6 hours every day in Jun 2011. If the rate per unit of electrical energy is 30 cents, calculate the cost of electrical energy used in that month.
Sebuah penyaman udara mempunyai kuasa dan kadar voltan 900 W, 240 V telah digunakan selama 6 jam setiap hari dalam bulan Jun 2011. Jika kadar satu unit tenaga elektrik ialah 30 sen, hitung kos tenaga elektrik yang digunakan dalam bulan tersebut.

Given :
Cost of electrical energy used
= Energy used in unit (kWh) x Cost per unit

Diberi :
Kos penggunaan tenaga elektrik
= Unit tenaga yang digunakan(kWh) x kos per unit

- A RM38.50
- B RM48.60
- C RM51.75
- D RM81.60

- 39 Diagram 31 shows the structure of the sun.
Rajah 31 menunjukkan struktur matahari.

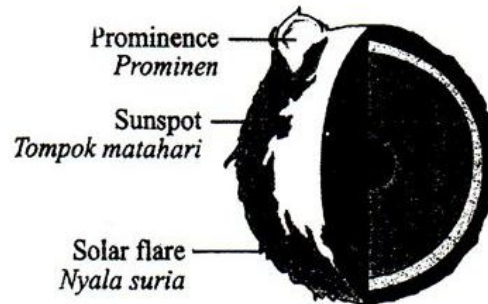

Diagram 31 / Rajah 31

- On which layer does the phenomena labelled above takes place?
Pada lapisan manakah fenomena-fenomena yang dilabelkan di atas berlaku?

- A Photosphere
Fotosfera
- B Core
Teras
- C Corona
Korona
- D Chromosphere
Kromosfera

- 40 The following statements is about the developments in space technology.
Pernyataan-pernyataan berikut adalah mengenai perkembangan dalam teknologi angkasa lepas.

- **To predict the weather**
Untuk membuat ramalan cuaca
- **To detect natural resources**
Untuk mengesan sumber-sumber semulajadi
- **To help navigating ships**
Untuk memberi petunjuk arah kepada kapal

- A **Satellite**
Satelit
- B **Telescope**
Teleskop
- C **Space shuttle**
Kapal angkasa ulang alik
- D **Probe**
Prob

END OF QUESTION PAPER
KERTAS SOALAN TAMAT

PEPERIKSAAN PERCUBAAN PMR 2011

SUGGESTED MARKING SCHEME

SCIENCE

PAPER ONE (55/1)

FORM THREE

QUESTION NO.	ANSWER	QUESTION NO.	ANSWER
1	C	21	C
2	C	22	D
3	D	23	D
4	D	24	B
5	A	25	B
6	C	26	D
7	A	27	B
8	B	28	C
9	A	29	C
10	C	30	B
11	A	31	B
12	D	32	A
13	B	33	B
14	C	34	A
15	C	35	A
16	D	36	B
17	C	37	B
18	C	38	B
19	D	39	A
20	A	40	A